

# 10.3.A(2)BH















Ultra-thin - from just 3.5mm - yet so strong it can be laid in 3m x 1m slabs on floors, walls or as an overlay. With low embodied carbon, up to 40% pre-consumer recycled content, flexible sizes and over one hundred colours and finishes, it's time to join the surface revolution. With a LEED and EPD certifications, it's a range perfectly in step with 21st century living.

To see the full range or download the Brochure, visit: [https://issuu.com/eftuk/docs/eco\\_friendly\\_tiles\\_surface\\_brochure](https://issuu.com/eftuk/docs/eco_friendly_tiles_surface_brochure)



## Bush-Hammered

### Properties

 Carbon Offset	 Chemical Resistant	 Frost Resistant	 Thermal Shock Resistant	 More Colours Available	 BREEAM	 EPD	 LEED	 SKA	 ISO 14001	 R10	 PTV 36	 UPTO 20% Recycled Content	 Pre Consumer Recycled Content
--	---	--	---	---	---	--	---	--	--	--	---	---	--

### Other formats

### Other finishes

### Sizes available

3.5mm †  Wall (with mesh)

5.6mm †  Floor / Wall / Overlay

5.6mm ‡  Floor / Wall / Overlay

6mm ‡  Floor / Wall / Overlay (with mesh)

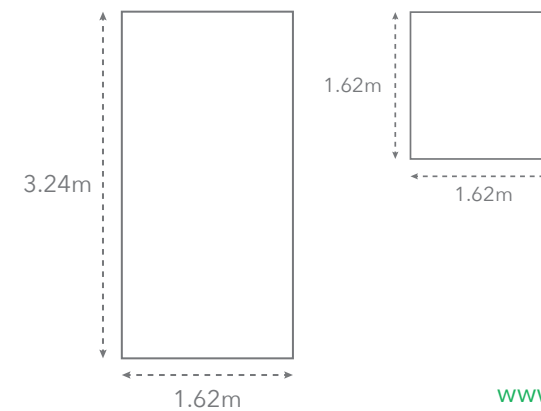
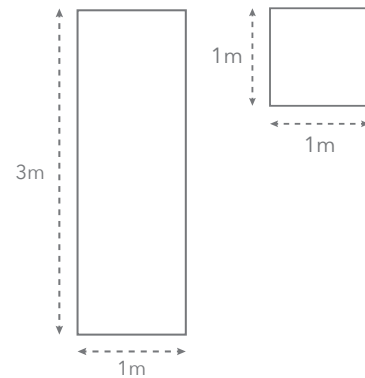

FOR OFFICE USE ONLY



Concrete Look  
BREEAM/LEED  
High Slip



Facade Code: 002 Concrete Pearl  
[www.ecofriendlyfacades.co.uk](http://www.ecofriendlyfacades.co.uk)



**ECO FRIENDLY TILES®**  
*The planet, covered*

[www.ecofriendlytiles.co.uk](http://www.ecofriendlytiles.co.uk)

Eco Friendly Tiles Ltd  
Ground Floor, Solon House  
40a Peterborough Road  
London  
SW6 3BN

0844 980 2233  
[info@ecofriendlytiles.co.uk](mailto:info@ecofriendlytiles.co.uk)  
[ecofriendlytiles.co.uk](http://ecofriendlytiles.co.uk)

# Technical Specification

## Code: 10.3.A(2)BH



Eco Friendly Tiles Limited  
 Ground Floor, Solon House  
 40a Peterborough Road  
 London  
 SW6 3BN  
 0844 980 2233  
 info@ecofriendlytiles.co.uk  
[www.ecofriendlytiles.co.uk](http://www.ecofriendlytiles.co.uk)

### Certifications



Physical & chemical properties	Norm/test method	Shannon 3.5mm
Straightness of sides	ISO 10545-2	Max. deviation on the side +/- 0.5mm
Difference between diagonals	Factory	Max. +/- 1.5mm
Weight	Factory	Average value 8.2kg/m <sup>2</sup>
Surface quality/% of tiles with no visible flaws	ISO 10545-2	> 95%
Water absorption	ISO 10545-3 / ASTM C373	Average value 0.1%
Breaking strength in N (samples 200x300mm)	ISO 10545-4	Average value 700
Modulus of rupture in N/mm <sup>2</sup> (samples 200x300mm)	ISO 10454-4	Average value 50
Resistance to deep abrasion	ISO 10545-6	≤ 175mm <sup>3</sup>
Coefficient of linear thermal expansion / 10 <sup>-6</sup> / 0 <sup>c</sup>	ISO 10545-8	Average value 6.6
Resistance to thermal shock	ISO 10545-9	Compliant
Resistance to freeze-thaw	ISO 10545-12	Compliant
Chemical resistance	ISO 10545-13	Class: from A to B
Stain resistance	ISO 10545-14	Class: from 4 to 5
Coefficient of friction	DIN 51130	R10
	BS 7976-2:2002 Pendulum	PTV 36+
Fire reaction	EN 13501 (rev. 2005)	A2 - s1, d0

This technical information sheet is not a guarantee of performance and is not a warranty, either explicit or implicit. Rather, it tries to summarize for the designer, installer or developer the technical data provided to Eco Friendly Tiles by the independent tile manufacturer. This information may not be applicable in all geographical areas. It is the responsibility of those individuals who are referring to this document to independently research and determine which tiles are suitable for a given project according to applicable British or International Standards and any governing legislative requirements. This document cannot be used as expert opinion, evidence or in any legal or administrative procedure unless authorized by Eco Friendly Tiles Ltd.

# Technical Specification

## Code: 10.3.A(2)BH



Eco Friendly Tiles Limited  
Ground Floor, Solon House  
40a Peterborough Road  
London  
SW6 3BN  
0844 980 2233  
info@ecofriendlytiles.co.uk  
[www.ecofriendlytiles.co.uk](http://www.ecofriendlytiles.co.uk)

### Certifications



Physical & chemical properties	Norm/test method	Shannon 5.6mm	Shannon 6mm
Length & Width (1000x3000 mm)	ISO 10545-2	Max. deviation on the side +/- 0.5mm	Max. deviation on the side +/- 0.5mm
(1200x3000 mm)	ISO 10545-2	Minimum size: ≥ 1210x3050 mm	Minimum size: ≥ 1210x3050 mm
(1620x3240 mm)	ISO 10545-2	Minimum size: ≥ 1630x3250 mm	Minimum size: ≥ 1630x3250 mm
Difference between diagonals	Factory	Max. +/- 1.5mm	Max. +/- 1.5mm
Weight	Factory	Average value 14.5kg/m <sup>2</sup>	Average value 14.9kg/m <sup>2</sup>
Surface quality/% of tiles with no visible flaws	ISO 10545-2	> 95%	> 95%
Water absorption	ISO 10545-3	Average Value ≤ 0.1%	Average Value ≤ 0.1%
Breaking strength in N (samples 1000x1000mm)	ISO 10545-4	Average value 1100	Average value 1100
Modulus of rupture in N/mm <sup>2</sup> (samples 1000x1000mm)	ISO 10454-4	Average value 50	Average value 50
Resistance to deep abrasion	ISO 10545-6	≤ 175mm <sup>3</sup>	≤ 175mm <sup>3</sup>
Coefficient of linear thermal expansion / 10 <sup>-6</sup> / 0 <sup>c</sup>	ISO 10545-8	Average value 6.6	Average value 6.6
Resistance to thermal shock	ISO 10545-9	Compliant	Compliant
Resistance to freeze-thaw	ISO 10545-12	Compliant	Compliant
Chemical resistance	ISO 10545-13	Class: from A to B	Class: from A to B
Stain resistance	ISO 10545-14	Class: from 4 to 5	Class: from 4 to 5
Coefficient of friction	DIN 51130	R10	R10
	BS 7976-2:2002 Pendulum	PTV 36+	PTV 36+
Fire reaction	EN 13501 (rev. 2005)	A1 (decision 96/603/CE as amended)	A2 - s1, d0